

# EYP-TPA-0850-01000-4006-CMT04-0000

## TAPERED AMPLIFIER

GaAs Semiconductor Laser Diode



### General Product Information

Product	Application
850 nm Tapered Amplifier	Raman Spectroscopy
C-Mount Package	Cs Spectroscopy
	Metrology

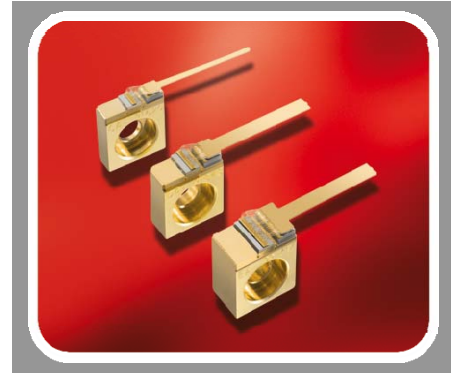

### Absolute Maximum Ratings

	Symbol	Unit	min	typ	max
Storage Temperature	$T_S$	°C	-40		85
Operational Temperature at Case	$T_C$	°C	0		50
Forward Current	$I_F$	A			3.0
Reverse Voltage	$V_R$	V			0
Output Power	$P_{opt}$	W			1.2

non condensing  
 non condensing  
 Stress in excess of the Absolute Maximum Ratings can cause permanent damage to the device. Operation at the Absolute Maximum Rating for extended periods of time can adversely affect the device reliability and may lead to reduced operational life.

### Recommended Operational Conditions

	Symbol	Unit	min	typ	max
Operational Temperature at Case	$T_C$	°C	0		40
Forward Current	$I_F$	A			2.8
Input Power	$P_{input}$	mW	10		50
Output Power	$P_{opt}$	W			1.0

Measurement Conditions / Comments  
 non condensing  
 with proper injection from a seed laser

### Characteristics at $T_{LD} = 25\text{ °C}$ at Begin Of Life

Parameter	Symbol	Unit	min	typ	max
Center Wavelength	$\lambda_c$	nm	840	850	860
Gain Width (FWHM)	$\Delta\lambda$	nm		20	
Temperature Coefficient of Wavelength	$d\lambda / dT$	nm / K		0.3	
Amplification	$P_{opt}$	dB		13	
Operational Current @ $P_{opt} = 1.0\text{ W}$	$I_{op\ Gain}$	A			2.8
Output Power @ $I_F = 2.8\text{ A}$	$P_{opt}$	W	1.0		
Cavity Length	L	$\mu\text{m}$		4000	

Measurement Conditions / Comments  
 see images on page 4  
 with proper injection from a seed laser

# EYP-TPA-0850-01000-4006-CMT04-0000



We focus on power.

Version 0.92

2009-09-18

page 2 from 5

## TAPERED AMPLIFIER

GaAs Semiconductor Laser Diode



RWE/RWL



BAL



DFB/DBR



TPL/TPA

### Characteristics at $T_{amb}$ 25 °C at Begin Of Life cont'd

Parameter	Symbol	Unit	min	typ	max
Input Aperture (at rear side)	$d_{input}$	$\mu m$		3	
Output Aperture (at front side)	$d_{output}$	$\mu m$		210	
Astigmatism	A	$\mu m$		600	
Divergence parallel (FWHM)	$\Theta_{  }$	$^{\circ}$		15	
Divergence perpendicular (FWHM)	$\Theta_{\perp}$	$^{\circ}$		28	
Polarization				TE	

### Measurement Conditions / Comments

depending on operating conditions

E field parallel to junction plane

**TAPERED AMPLIFIER**  
GaAs Semiconductor Laser Diode



**Package Dimensions**



Parameter	Symbol	Unit	min	typ	max
Height of Emission Plane	h	mm	7.05	7.20	7.35
C-Mount Thickness	t	mm		4.15	

Measurement Conditions / Comments



**Package Pinout**

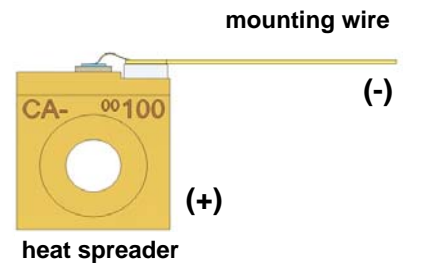

Cathode (-)	Mounting Wire
Anode (+)	Housing

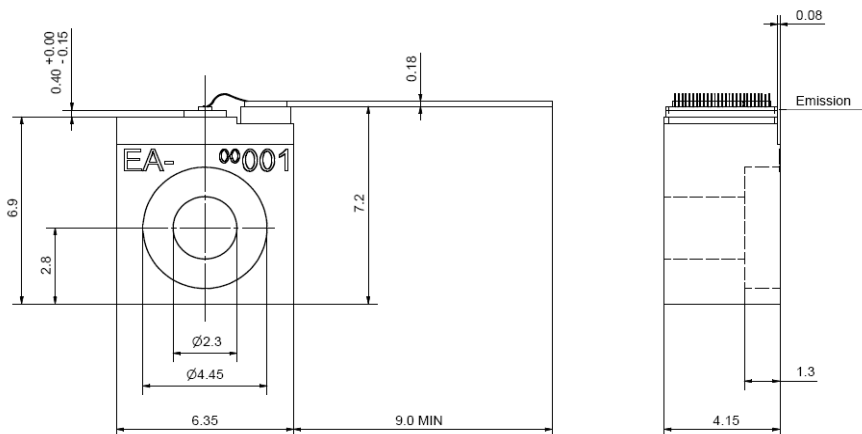

**Package Drawings**



Z07-0000-CMT04-BAL-DATA

# EYP-TPA-0850-01000-4006-CMT04-0000



We focus on power.

Version 0.92

2009-09-18

page 4 from 5

## TAPERED AMPLIFIER

GaAs Semiconductor Laser Diode



### Typical Measurement Results



Spectrum seeded at 852 nm

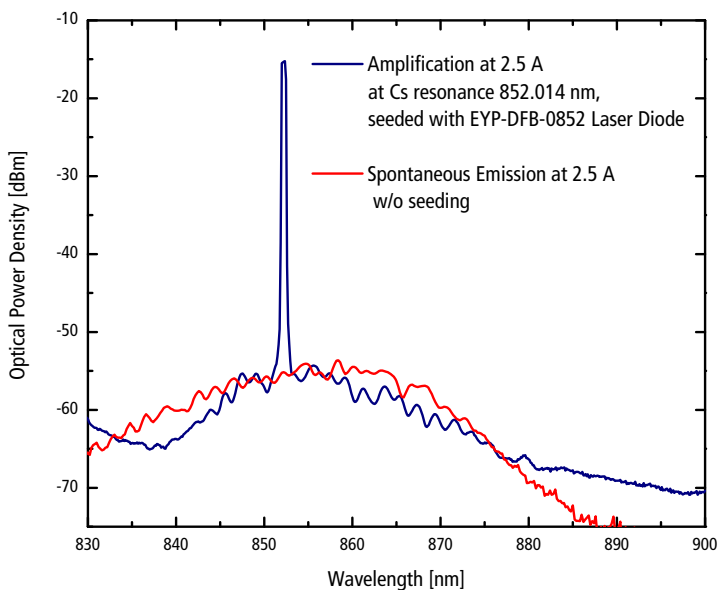

Performance figures, data and any illustrative material provided in this specification are typical and must be specifically confirmed in writing by eagleyard Photonics before they become applicable to any particular order or contract. In accordance with the eagleyard Photonics policy of continuous improvement specifications may change without notice.

P-I-Curve seeded at 852 nm

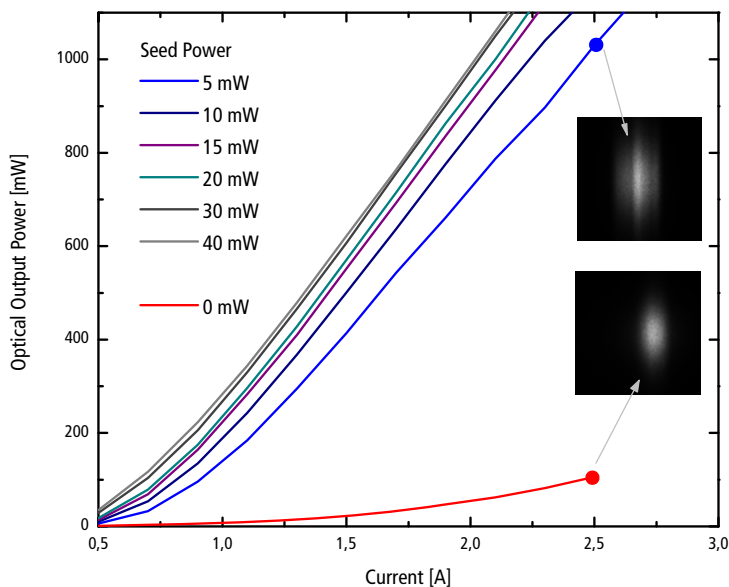

# EYP-TPA-0850-01000-4006-CMT04-0000



We focus on power.

Version 0.92

2009-09-18

page 5 from 5

## TAPERED AMPLIFIER

GaAs Semiconductor Laser Diode



### Unpacking, Installation and Laser Safety

Unpacking the laser diodes should only be done at electrostatic safe workstations (EPA). Though protection against electro static discharge (ESD) is implemented in the laser package, charges may occur at surfaces. Please store this product in its original package at a dry, clean place until final use. During device installation, ESD protection has to be maintained.

The TPA diode type is known to be sensitive against thermal stress. It should not be operated without appropriate injection from a seed laser. Operating at moderate temperatures on proper heat sinks will contribute to a long lifetime of the diode.

The laser emission from this diode is close to the invisible infrared region of the electromagnetic spectrum. Avoid direct and/or indirect exposure to the free running beam. Collimating the free running beam with optics as common in optical instruments will increase threat to the human eye.

Each laser diode will come with an individual test protocol verifying the parameters given in this document.

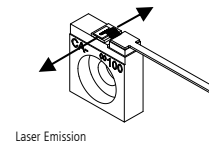

Laser Emission

