

EYP-BAL-1064-10000-4020-CDL02-0000



We focus on power.

Revision 1.03

22.09.2016

page 1 of 4

BROAD AREA LASER

GaAs Semiconductor Laser Diode
Single Emitter Structure



General Product Information

Product	Application
1064 nm Broad Area Laser	Medical
with Collimating Double Lens	Material Processing
Thermistor	

Absolute Maximum Ratings

	Symbol	Unit	min	typ	max
Storage Temperature	T_S	°C	-20		70
Operational Temperature at Case	T_C	°C	5		40
Forward Current	I_F	A			20
Reverse Voltage	V_R	V			2
Output Power	P_{opt}	W			12

Recommended Operational Conditions

	Symbol	Unit	min	typ	max
Operational Temperature at Case	T_C	°C	15		30
Forward Current	I_F	A			18
Output Power	P_{opt}	W			10

Characteristics at $T_{LD} = 25\text{ °C}$ at Begin Of Life

Parameter	Symbol	Unit	min	typ	max
Center Wavelength	λ_C	nm	1049	1064	1079
Spectral Width (FWHM)	$\Delta\lambda$	nm			6
Temperature Coefficient of Wavelength	$d\lambda / dT$	nm / K		0.4	
Output Power @ $I_F = 18\text{ A}$	P_{opt}	W	10		
Slope Efficiency	η_d	W / A	0.6	0.7	
Threshold Current	I_{th}	A		2.0	2.5
Operational Current @ $P_{opt} = 10\text{ W}$	I_{op}	A			18
Voltage at Threshold	U_{th}	V	1.2		
Operational Voltage	U	V	1.4	1.8	2.2

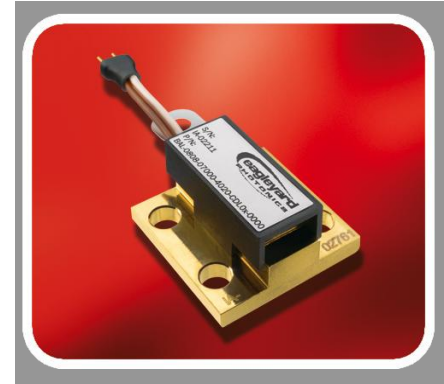

non condensing
non condensing
Stress in excess of one of the Absolute Maximum Ratings can cause permanent damage to the device.

Measurement Conditions / Comments
non condensing

Measurement Conditions / Comments
 $P_{opt} = 15\text{ W}$

total output measured with integrating sphere

$I_F = I_{th}$
 $P_{opt} = 10\text{ W}$

EYP-BAL-1064-10000-4020-CDL02-0000

BROAD AREA LASER

GaAs Semiconductor Laser Diode
Single Emitter Structure



Characteristics at T_{amb} 25 °C at Begin Of Life cont'd

Parameter	Symbol	Unit	min	typ	max
Differential Serial Resistance	R_s	m Ω	20	40	60
Stripe Width	W_s	μ m		200	
Cavity Length	L	μ m		4000	
Divergence parallel	$\Theta_{ }$	°	1.0	1.5	2.0
Divergence perpendicular	Θ_{\perp}	°	0.4	0.6	0.8
Beam Width parallel	$S_{ }$	mm	2	3	4
Beam Width perpendicular	F_{\perp}	mm	0.2	0.4	0.6
Spectral Mode (longitudinal)				Multi Mode	
Polarization				TE	

Measurement Conditions / Comments

Second Moment Full Angle

Second Moment Full Angle

Polarization parallel to base plate

ESD-Resistor

Parameter	Symbol	Unit	min	typ	max
Resistance	R_{ESD}	k Ω		1	

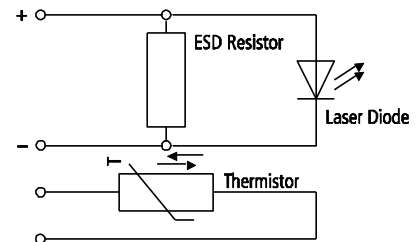

Thermistor (Standard NTC Type)

Parameter	Symbol	Unit	min	typ	max
Resistance	R	k Ω		10	
Beta Coefficient	β			4000	

$T_c = 25^\circ C$

EYP-BAL-1064-10000-4020-CDL02-0000

BROAD AREA LASER

GaAs Semiconductor Laser Diode
Single Emitter Structure



Package Dimensions

Parameter	Symbol	Unit	min	typ	max
Emission Plane	h_{EP}	mm	7.75	7.85	7.95
CDL Package Footprint	w x l	mm x mm		25 x 25	

Measurement Conditions / Comments

Package Pinout

Cathode (-)	Cable
Anode (+)	Housing
NTC	NTC Connector

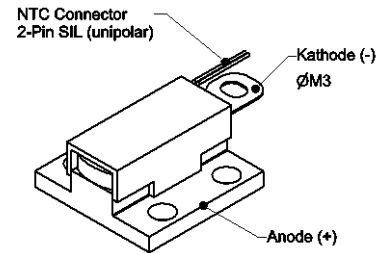

Package Drawings

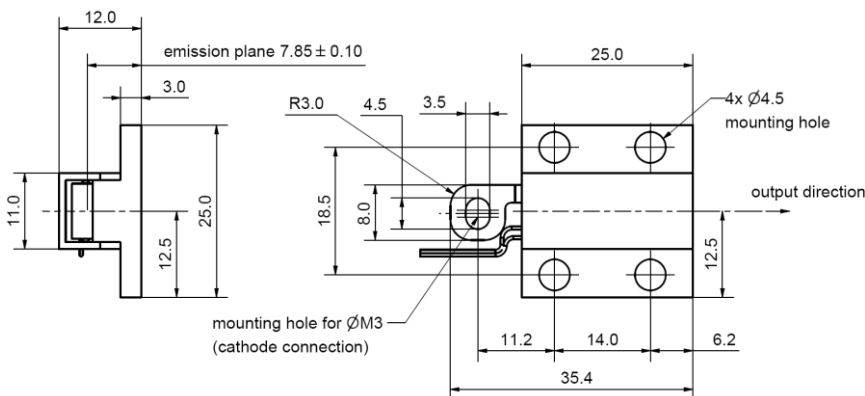

Z11-SPEC-CDL02-BAL-0000

EYP-BAL-1064-10000-4020-CDL02-0000



We focus on power.

Revision 1.03

22.09.2016

page 4 of 4

BROAD AREA LASER

GaAs Semiconductor Laser Diode
Single Emitter Structure



Typical Measurement Results

Emission Spectrum:

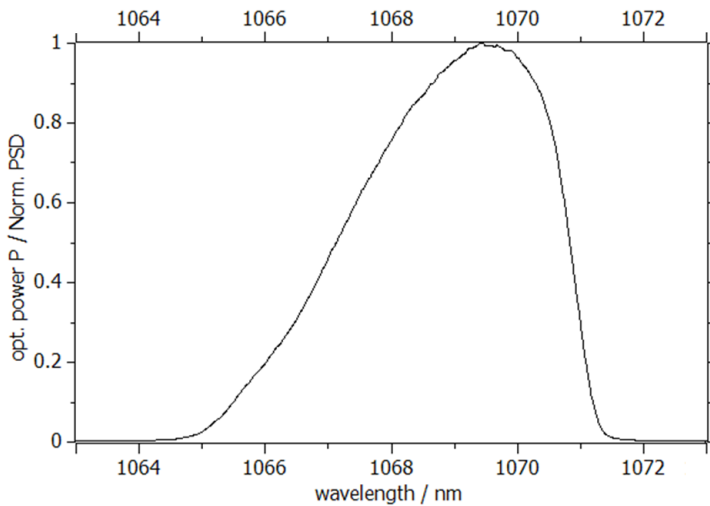

Performance figures, data and any illustrative material provided in this specification are typical and must be specifically confirmed in writing by eagleyard Photonics before they become applicable to any particular order or contract. In accordance with the eagleyard Photonics policy of continuous improvement specifications may change without notice.

Unpacking, Installation and Laser Safety

Unpacking the laser diodes should only be done at electrostatic safe workstations (EPA). Though protection against electro static discharge (ESD) is implemented in the laser package, charges may occur at surfaces. Please store this product in its original package at a dry, clean place until final use. During device installation, ESD protection has to be maintained.

The BAL diode type is known to be sensitive against thermal stress. Operating at moderate temperatures on proper heat sinks will contribute to a long lifetime of the diode. The chip should be protected against moisture. A water vapor content below 5000 ppm is recommended for applications with high reliability requirements.

The laser emission from this diode is close to the invisible infrared region of the electromagnetic spectrum. Avoid direct and/or indirect exposure to the free running beam. Collimating the free running beam with optics as common in optical instruments will increase threat to the human eye.

Each laser diode will come with an individual test protocol verifying the parameters given in this document.

