

EYP-BAL-0760-01500-2010-CMT02-0000

BROAD AREA LASER

GaAs Semiconductor Laser Diode
Single Emitter Structure



General Product Information

Product	Application
760 nm Broad Area Laser	Material Processing
mounted on C-Mount	Medical

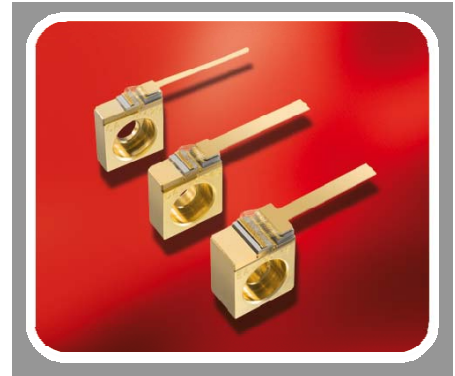

Absolute Maximum Ratings

	Symbol	Unit	min	typ	max
Storage Temperature	T_S	°C	-40		85
Operational Temperature at Case	T_C	°C	-20		50
Forward Current	I_F	A			2.0
Reverse Voltage	V_R	V			0
Output Power	P_{opt}	W			1.6

non condensing
non condensing
Stress in excess of the Absolute Maximum Ratings can cause permanent damage to the device.

Recommended Operational Conditions

	Symbol	Unit	min	typ	max
Operational Temperature at Case	T_C	°C	10		25
Forward Current	I_F	A			1.8
Output Power	P_{opt}	W			1.5

Measurement Conditions / Comments
non condensing

Characteristics at $T_{LD} = 20\text{ °C}$ at Begin Of Life

Parameter	Symbol	Unit	min	typ	max
Center Wavelength	λ_C	nm	757	760	763
Spectral Width (FWHM)	$\Delta\lambda$	nm		2	
Temperature Coefficient of Wavelength	$d\lambda / dT$	nm / K		0.3	
Output Power @ $I_F = 1.8\text{ A}$	P_{opt}	W	1.5		
Slope Efficiency	η_d	W / A		1.0	
Threshold Current	I_{th}	A	0.35	0.45	0.50
Operational Current @ $P_{opt} = 1.5\text{ W}$	I_{op}	A			1.8
Stripe Width	W_s	μm		100	
Cavity Length	L	μm		2000	

Measurement Conditions / Comments
see images on page 4

total output measured with integrating sphere

EYP-BAL-0760-01500-2010-CMT02-0000



We focus on power.

Version 0.90

2009-04-16 page 2 from 4

BROAD AREA LASER

GaAs Semiconductor Laser Diode
Single Emitter Structure



RWE/RWL



BAL



DFB/DBR



TPL/TPA

Characteristics at T_{amb} 20 °C at Begin Of Life cont'd

Parameter	Symbol	Unit	min	typ	max
Divergence parallel (FWHM)	$\Theta_{ }$	°		8	
Divergence perpendicular (FWHM)	Θ_{\perp}	°		27	
Spectral Mode (longitudinal)				Multi Mode	
Polarization				TM	

Measurement Conditions / Comments

Beam divergence parallel to junction plane

Beam divergence perpendicular to junction plane

Polarization perpendicular to junction plane



EYP-BAL-0760-01500-2010-CMT02-0000

Version 0.90

2009-04-16 page 3 from 4

BROAD AREA LASER

GaAs Semiconductor Laser Diode
Single Emitter Structure



Package Dimensions

Parameter	Symbol	Unit	min	typ	max
Height of Emission Plane	h_{EP}	mm	7.05	7.20	7.35
C-Mount Thickness	d	mm		2.18	

Measurement Conditions / Comments

Package Pinout

Cathode (-)	Mounting Wire
Anode (+)	Housing

mounting wire

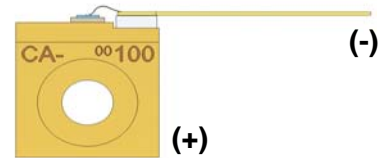

heat spreader

Package Drawings

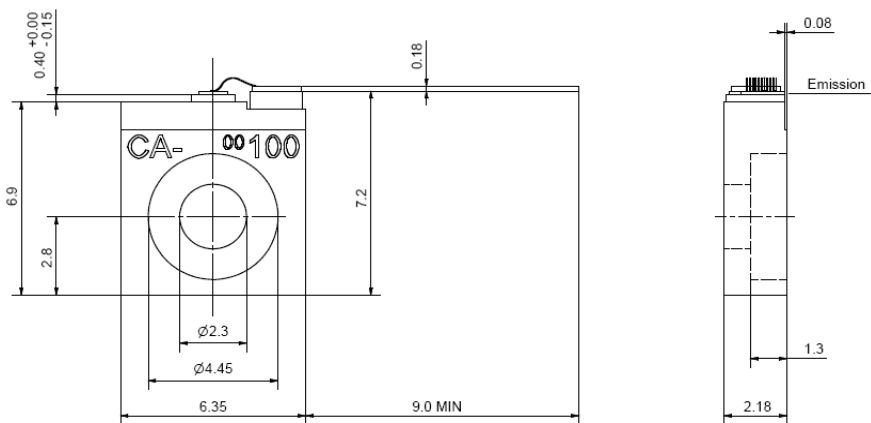

EYP-BAL-0760-01500-2010-CMT02-0000



We focus on power.

Version 0.90

2009-04-16 page 4 from 4

BROAD AREA LASER

GaAs Semiconductor Laser Diode
Single Emitter Structure



Typical Measurement Results

tbd

Performance figures, data and any illustrative material provided in this specification are typical and must be specifically confirmed in writing by eagleyard Photonics before they become applicable to any particular order or contract. In accordance with the eagleyard Photonics policy of continuous improvement specifications may change without notice.

Unpacking, Installation and Laser Safety

Unpacking the laser diodes should only be done at electrostatic safe workstations (EPA). Though protection against electro static discharge (ESD) is implemented in the laser package, charges may occur at surfaces. Please store this product in its original package at a dry, clean place until final use. During device installation, ESD protection has to be maintained.

The BAL diode type is known to be sensitive against thermal stress. Operating at moderate temperatures on proper heat sinks will contribute to a long lifetime of the diode.

The laser emission from this diode is close to the invisible infrared region of the electromagnetic spectrum. Avoid direct and/or indirect exposure to the free running beam. Collimating the free running beam with optics as common in optical instruments will increase threat to the human eye.

Each laser diode will come with an individual test protocol verifying the parameters given in this document.

