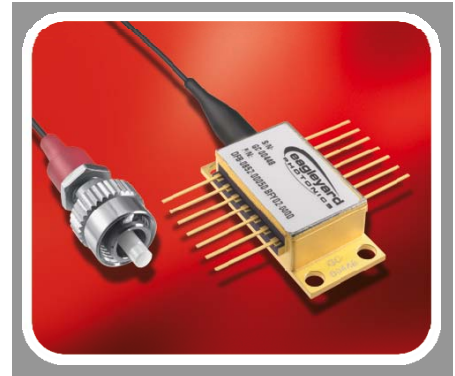

DISTRIBUTED FEEDBACK LASER

GaAs Semiconductor Laser Diode
with integrated grating structure

**General Product Information**

Product	Application
1060 nm DFB Laser with hermetic Butterfly Housing	Spectroscopy
Monitor Diode, Thermoelectric Cooler and Thermistor	Metrology
PM Fiber with angle-polished Connector	
High-reliable fully Space-qualified Package	

**Absolute Maximum Ratings**

	Symbol	Unit	min	typ	max
Storage Temperature	T_S	°C	-40		85
Operational Temperature at Case	T_C	°C	-40		85
Operational Temperature at Laser Chip	T_{LD}	°C	10		50
Forward Current	I_F	mA			250
Reverse Voltage	V_R	V			0
Output Power	P_{opt}	mW			50
TEC Current	I_{TEC}	A			1.8
TEC Voltage	V_{TEC}	V			3.2

Stress in excess of the Absolute Maximum Ratings can cause permanent damage to the device.

Recommended Operational Conditions

	Symbol	Unit	min	typ	max
Operational Temperature at Case	T_C	°C	-20		65
Operational Temperature at Laser Chip	T_{LD}	°C	15		40
Forward Current	I_F	mA			230
Output Power	P_{opt}	mW	10		40

Measurement Conditions / Comments

measured by integrated Thermistor

ex fiber

Characteristics at $T_{LD} = 25\text{ °C}$ at Begin Of Life

Parameter	Symbol	Unit	min	typ	max
Center Wavelength	λ_C	nm	1059	1060	1061
Spectral Width (FWHM)	$\Delta\nu$	MHz		2	
Temperature Coefficient of Wavelength	$d\lambda / dT$	nm / K		0.06	
Current Coefficient of Wavelength	$d\lambda / dI$	nm / mA		0.003	
Output Power @ $I_F = 230\text{ mA}$	P_{opt}	mW	40		

Measurement Conditions / Comments

see images on page 4

ex fiber

EYP-DFB-1060-00040-1500-BFY02-0000

We focus on power.

Version 1.02

2009-01-07

page 2 from 5

DISTRIBUTED FEEDBACK LASER

GaAs Semiconductor Laser Diode
with integrated grating structure



RWE/RWL



BAL



DFB/DBR



TPL/TPA

Characteristics at $T_{amb} = 25\text{ °C}$ at Begin Of Life cont'd

Parameter	Symbol	Unit	min	typ	max
Slope Efficiency	S	W / A	0.2	0.4	0.7
Threshold Current	I_{th}	mA			70
Sidemode Suppression Ratio	SMSR	dB	30	45	
Mode-hop free Temperature Range (SMSR > 30 dB)					
▶ Variant 0	T_{LD}	°C		25	
▶ Variant 1	T_{LD}	°C		25	
▶ Variant 2	T_{LD}	°C	15		40
Mode-hop free Power Range (SMSR > 30 dB)					
▶ Variant 0	P_{opt}	mW		40	
▶ Variant 1	P_{opt}	mW	10		40
▶ Variant 2	P_{opt}	mW	10		40
Polarization Extinction Ratio	PER	dB		20	
Spatial Mode (transversal)				TEM_{00}	

Measurement Conditions / Comments

see below

Temperature at Laser Chip
see order code scheme on p. 5

SMSR > 30 dB
see order code scheme on p. 5

$P_{opt} = 40\text{ mW}$
fundamental mode

Monitor Diode

Parameter	Symbol	Unit	min	typ	max
Monitor Detector Responsivity	I_{mon} / P_{opt}	$\mu\text{A} / \text{mW}$	1		20
Reverse Voltage Monitor Diode	$U_{R,MD}$	V	3		5

Measurement Conditions / Comments

 $U_R = 5\text{ V}$, target values

Thermoelectric Cooler

Parameter	Symbol	Unit	min	typ	max
Current	I_{TEC}	A		0.4	
Voltage	U_{TEC}	V		0.8	
Power Dissipation (total loss at case)	P_{loss}	W		0.5	
Temperature Difference	ΔT	K			50

Measurement Conditions / Comments

 $P_{opt} = 40\text{ mW}$, $\Delta T = 20\text{ K}$ $P_{opt} = 40\text{ mW}$, $\Delta T = 20\text{ K}$ $P_{opt} = 40\text{ mW}$, $\Delta T = 20\text{ K}$ $P_{opt} = 40\text{ mW}$, $\Delta T = |T_{case} - T_{LD}|$

Thermistor (Standard NTC Type)

Parameter	Symbol	Unit	min	typ	max
Resistance	R	kOhm		10	
Beta Coefficient	β			3892	

Measurement Conditions / Comments

EYP-DFB-1060-00040-1500-BFY02-0000

We focus on power.

Version 1.02

2009-01-07

page 3 from 5

DISTRIBUTED FEEDBACK LASER

GaAs Semiconductor Laser Diode
with integrated grating structure



Fiber and Connector Type

PM Fiber	900 / 125 / 5.5 μm , UV/Polyamide Coating ($l = 1 \pm 0.1 \text{ m}$)
Connector	different variants available <ul style="list-style-type: none"> ▶ FC/APC (narrow key / 2mm) ▶ SC/APC ▶ other types on request

Measurement Conditions / Comments

see order code scheme

Package Pinout

1	Thermoelectric Cooler (+)	14	Thermoelectric Cooler (-)
2	Thermistor	13	Case
3	Photodiode (Anode)	12	not connected
4	Photodiode (Cathode)	11	Laser Diode (Cathode)
5	Thermistor	10	Laser Diode (Anode)
6	not connected	9	not connected
7	not connected	8	not connected

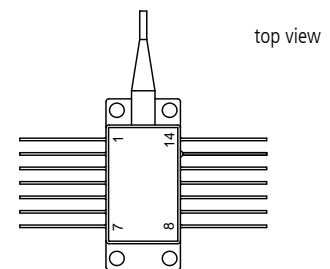

Package Drawings

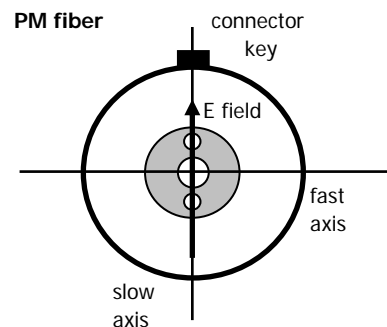
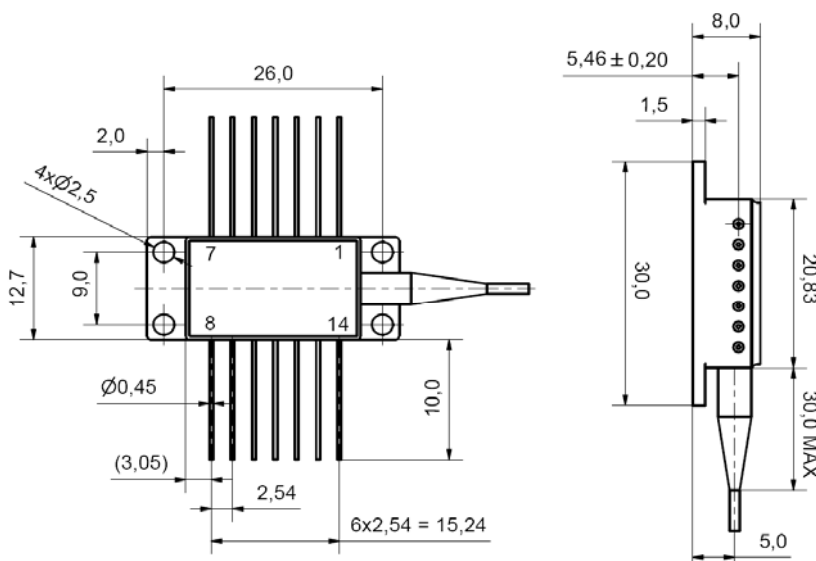

slow axis of the PM fiber aligned to connector key

hermetically sealed Package:

Leak Rate $< 5 \cdot 10^{-8}$ atm.cc./s
acc. MIL-STD-883E

EYP-DFB-1060-00040-1500-BFY02-0000

DISTRIBUTED FEEDBACK LASER

GaAs Semiconductor Laser Diode
with integrated grating structure



RWE/RWL



BAL



DFB/DBR



TPL/TPA

Typical Measurement Results

Output Power vs. Current

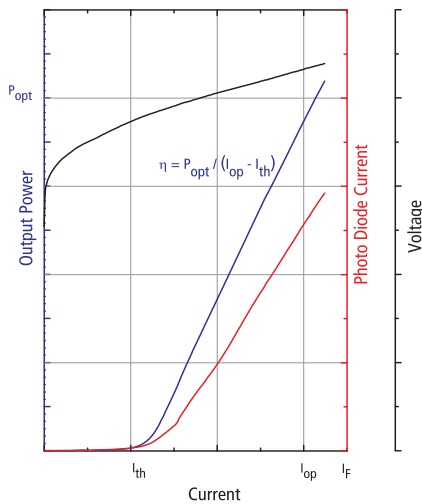

Spectra at Specified Optical Output Power

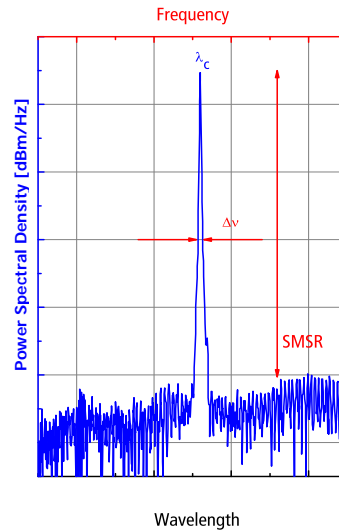

Performance figures, data and any illustrative material provided in this specification are typical and must be specifically confirmed in writing by eagleyard Photonics before they become applicable to any particular order or contract. In accordance with the eagleyard Photonics policy of continuous improvement specifications may change without notice.

EYP-DFB-1060-00040-1500-BFY02-0000



We focus on power.

Version 1.02

2009-01-07

page 5 from 5

DISTRIBUTED FEEDBACK LASER

GaAs Semiconductor Laser Diode
with integrated grating structure



Order Code Scheme

Connector

FC/APC (narrow key / 2mm)

SC/APC

other connector or fiber types upon request

Mode-hop free Tuning Range (Minimum Side Mode Suppression Ratio > 30 dB)

$P_{opt} = 40 \text{ mW}$; $T_{LD} = 25^\circ$ (Variant 0)

$P_{opt} = 10 \dots 40 \text{ mW}$; $T_{LD} = 25^\circ$ (Variant 1)

$P_{opt} = 10 \dots 40 \text{ mW}$; $T_{LD} = 15^\circ \dots 40^\circ \text{ C}$ (Variant 2)

EYP-DFB-1060-00040-1500-BFY02- 0 x 0 x

0
1

0
1
2

Unpacking, Installation and Laser Safety

Unpacking the laser diodes should only be done at electrostatic safe workstations (EPA). Though protection against electro static discharge (ESD) is implemented in the laser package, charges may occur at surfaces. Please store this product in its original package at a dry, clean place until final use. During device installation, ESD protection has to be maintained.

The DFB diode type is known to be sensitive against optical feedback, so an optical isolator may be required in some cases. Operating at moderate temperatures on a proper metal heat sinks will contribute to stable operation and a long lifetime of the diode.

The laser emission from this diode is close to the invisible infrared region of the electromagnetic spectrum. Avoid direct and/or indirect exposure to the free running beam. Collimating the free running beam with optics as common in optical instruments will increase threat to the human eye.

Each laser diode will come with an individual test protocol verifying the parameters given in this document.

