

EYP-DFB-0855-00150-1500-TOC03-000x

Version 0.91

2009-10-09

page 1 from 5

DISTRIBUTED FEEDBACK LASER

GaAs Semiconductor Laser Diode
with integrated grating structure



General Product Information

Product	Application
855 nm DFB Laser with hermetic TO Housing	Spectroscopy
Monitor Diode, Thermoelectric Cooler and Thermistor	Metrology
	THz Generation

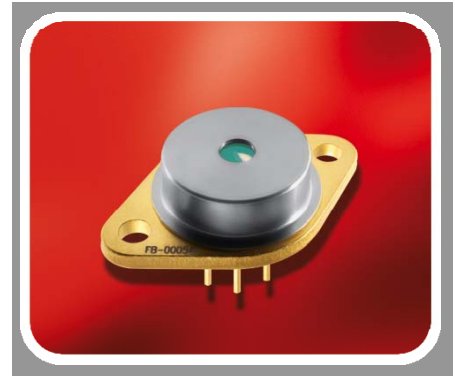

Absolute Maximum Ratings

	Symbol	Unit	min	typ	max
Storage Temperature	T_S	°C	-40		85
Operational Temperature at Case	T_C	°C	-20		75
Operational Temperature at Laser Chip	T_{LD}	°C	10		50
Forward Current	I_F	mA			220
Reverse Voltage	V_R	V			0
Output Power	P_{opt}	mW			160
TEC Current	I_{TEC}	A			1.8
TEC Voltage	V_{TEC}	V			3.2

Stress in excess of the Absolute Maximum Ratings can cause permanent damage to the device.

Recommended Operational Conditions

	Symbol	Unit	min	typ	max
Operational Temperature at Case	T_C	°C	-20		65
Operational Temperature at Laser Chip	T_{LD}	°C	15		40
Forward Current	I_F	mA			200
Output Power	P_{opt}	mW	20		150

Measurement Conditions / Comments

measured by integrated Thermistor

Characteristics at $T_{LD} = 25\text{ °C}$ at Begin Of Life

Parameter	Symbol	Unit	min	typ	max
Center Wavelength	λ_c	nm	854	855	856
Spectral Width (FWHM)	$\Delta\nu$	MHz		2	
Temperature Coefficient of Wavelength	$d\lambda / dT$	nm / K		0.06	
Current Coefficient of Wavelength	$d\lambda / dI$	nm / mA		0.003	
Output Power @ $I_F = 200\text{ mA}$	P_{opt}	mW	150		
Slope Efficiency	S	W / A	0.6	0.8	1.0

Measurement Conditions / Comments

see images on page 4

DISTRIBUTED FEEDBACK LASER

GaAs Semiconductor Laser Diode
with integrated grating structure



RWE/RWL



BAL



DFB/DBR



TPL/TPA

Characteristics at T_{amb} 25 °C at Begin Of Life cont'd

Parameter	Symbol	Unit	min	typ	max
Threshold Current	I_{th}	mA			70
Divergence parallel (FWHM)	$\Theta_{ }$	°		8	
Divergence perpendicular (FWHM)	Θ_{\perp}	°		21	
Sidemode Suppression Ratio	SMSR	dB	30	45	
Mode-hop free Temperature Range (SMSR > 30 dB)					
▶ Variant 0	T_{LD}	°C		25	
▶ Variant 1	T_{LD}	°C		25	
▶ Variant 2	T_{LD}	°C	15		40
Mode-hop free Power Range (SMSR > 30 dB)					
▶ Variant 0	P_{opt}	mW		150	
▶ Variant 1	P_{opt}	mW	20		150
▶ Variant 2	P_{opt}	mW	20		150
Polarization Extinction Ratio	PER	dB		20	
Spatial Mode (transversal)				TEM ₀₀	

Measurement Conditions / Comments

parallel to short axis of the housing (see p. 3)

parallel to long axis of the housing (see p. 3)

see below

Temperature at Laser Chip

see order code scheme on p. 5

SMSR > 30 dB

see order code scheme on p. 5

$P_{opt} = 150$ mW; E field parallel to short axis of housing
fundamental mode

Monitor Diode

Parameter	Symbol	Unit	min	typ	max
Monitor Detector Responsivity	I_{mon} / P_{opt}	μA / mW	0.5		10
Reverse Voltage Monitor Diode	U_{RMD}	V	3		5

Measurement Conditions / Comments $U_R = 5$ V, target values**Thermoelectric Cooler**

Parameter	Symbol	Unit	min	typ	max
Current	I_{TEC}	A		0.4	
Voltage	U_{TEC}	V		0.8	
Power Dissipation (total loss at case)	P_{loss}	W		0.5	
Temperature Difference	ΔT	K			50

Measurement Conditions / Comments $P_{opt} = 150$ mW, $\Delta T = 20$ K $P_{opt} = 150$ mW, $\Delta T = 20$ K $P_{opt} = 150$ mW, $\Delta T = 20$ K $P_{opt} = 150$ mW, $\Delta T = |T_{case} - T_{LD}|$ **Thermistor (Standard NTC Type)**

Parameter	Symbol	Unit	min	typ	max
Resistance	R	kOhm		10	
Beta Coefficient	β			3892	

Measurement Conditions / Comments

EYP-DFB-0855-00150-1500-TOC03-000x



We focus on power.

Version 0.91

2009-10-09

page 3 from 5

DISTRIBUTED FEEDBACK LASER

GaAs Semiconductor Laser Diode
with integrated grating structure



Package Dimensions

Parameter	Symbol	Unit	min	typ	max
Height of Laser Output above Header	H_L	mm		5.1	
Housing Dimension	$l \times w \times h$	mm ³		38.9 x 25.4 x 9.3	
Pin Length	L	mm	10.8		

Measurement Conditions / Comments

Package Pinout

1	Thermoelectric Cooler (+)	5	Laser Diode (Anode)
2	Thermistor	6	Photo Diode (Anode)
3	Thermistor	7	Photo Diode (Cathode)
4	Laser Diode (Cathode)	8	Thermoelectric Cooler (-)

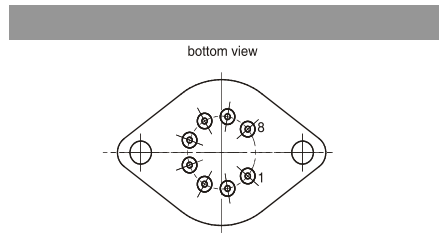

Package Drawings

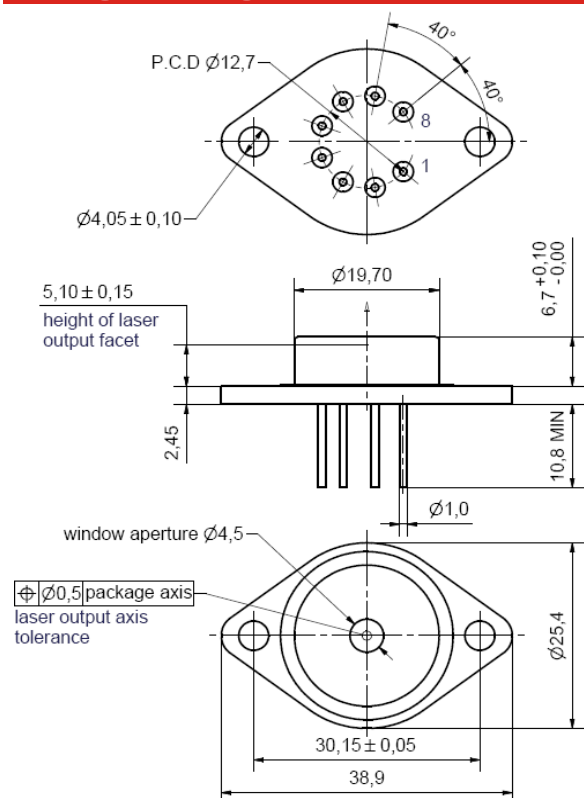

Polarization:

E field parallel to short axis of housing

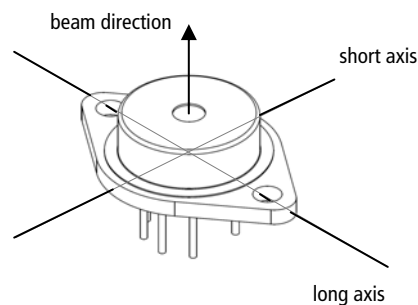

hermetically sealed Package:

Leak Rate $< 5 \cdot 10^{-8}$ atm.cc./s
acc. MIL-STD-883E



EYP-DFB-0855-00150-1500-TOC03-000x



We focus on power.

Version 0.91

2009-10-09

page 4 from 5

DISTRIBUTED FEEDBACK LASER

GaAs Semiconductor Laser Diode
with integrated grating structure



RWE/RWL



BAL



DFB/DBR



TPL/TPA

Typical Measurement Results

Output Power vs. Current

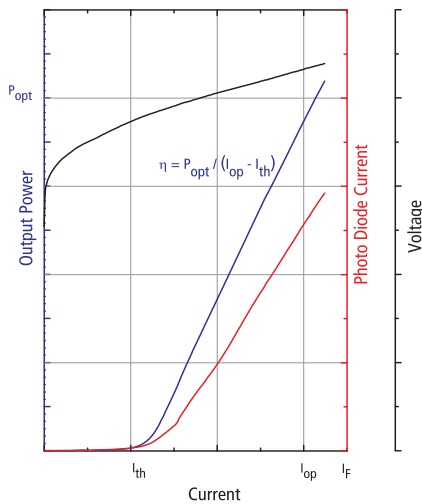

Spectra at Specified Optical Output Power

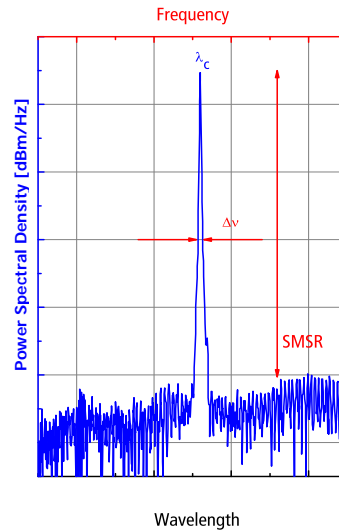

Performance figures, data and any illustrative material provided in this specification are typical and must be specifically confirmed in writing by eagleyard Photonics before they become applicable to any particular order or contract. In accordance with the eagleyard Photonics policy of continuous improvement specifications may change without notice.



EYP-DFB-0855-00150-1500-TOC03-000x



We focus on power.

Version 0.91

2009-10-09

page 5 from 5

DISTRIBUTED FEEDBACK LASER

GaAs Semiconductor Laser Diode
with integrated grating structure



Order Code Scheme

EYP-DFB-0855-00150-1500-TOC03- 0 0 0 x

Mode-hop free Tuning Range (Minimum Side Mode Suppression Ratio > 30 dB)

$P_{opt} = 150 \text{ mW};$	$T_{LD} = 25^\circ$	(Variant 0)
$P_{opt} = 20 \dots 150 \text{ mW};$	$T_{LD} = 25^\circ$	(Variant 1)
$P_{opt} = 20 \dots 150 \text{ mW};$	$T_{LD} = 15^\circ \dots 40^\circ \text{ C}$	(Variant 2)

x
0
1
2

Unpacking, Installation and Laser Safety

Unpacking the laser diodes should only be done at electrostatic safe workstations (EPA). Though protection against electro static discharge (ESD) is implemented in the laser package, charges may occur at surfaces. Please store this product in its original package at a dry, clean place until final use. During device installation, ESD protection has to be maintained.

The DFB diode type is known to be sensitive against optical feedback, so an optical isolator may be required in some cases. Operating at moderate temperatures on proper heat sinks will contribute to a long lifetime of the diode.

The laser emission from this diode is close to the invisible infrared region of the electromagnetic spectrum. Avoid direct and/or indirect exposure to the free running beam. Collimating the free running beam with optics as common in optical instruments will increase threat to the human eye.

Each laser diode will come with an individual test protocol verifying the parameters given in this document.

