

**DISTRIBUTED BRAGG REFLECTOR LASER**

GaAs Semiconductor Laser Diode  
with integrated grating structure



## PRELIMINARY SPECIFICATION

## DBR Laser

**EYP-DBR-1080-00080-2000-TOC03-0000****General Product Information**

Product	Application
1080 nm DFB Laser with TO Housing	Spectroscopy
Monitor Diode, Thermoelectric Cooler and Thermistor	Metrology

**Absolute Maximum Ratings**

	Symbol	Unit	min	typ	max
Storage Temperature	$T_S$	°C	-40		85
Operational Temperature at Case	$T_C$	°C	-20		75
Forward Current	$I_F$	mA			220
Reverse Voltage	$V_R$	V			0
Output Power	$P_{opt}$	mW			100

**Recommended Operational Conditions**

	Symbol	Unit	min	typ	max
Temperature at Laser Chip	$T_{LD}$	°C	15		40
Forward Current	$I_F$	mA			200
Output Power	$P_{opt}$	mW	10		80

**Characteristics at  $T_{amb}$  25 °C at Begin Of Life**

Parameter	Symbol	Unit	min	typ	max
Center Wavelength	$\lambda_C$	nm	1079	1080	1082
Spectral Width (FWHM)	$\Delta\nu$	MHz		2	10
Temperature Coefficient of Wavelength	$d\lambda / dT$	nm / K		0.06	
Current Coefficient of Wavelength	$d\lambda / dI$	nm / mA		0.003	
Output Power @ $I_F = 200$ mA	$P_{opt}$	mW	80		
Slope Efficiency	$S$	W / A	0.6	0.8	1.0

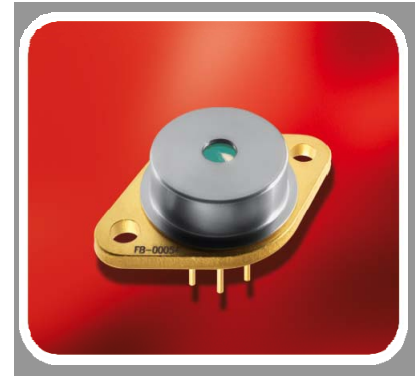

Stress in excess of the Absolute Maximum Ratings can cause permanent damage to the device. Operation at the Absolute Maximum Rating for extended periods of time can adversely affect the device reliability and may lead to reduced operational life.

measured by thermistor

total output measured with integrated sphere

**Measurement Conditions / Comments**

see images on page 4

total output measured with integrated sphere

**DISTRIBUTED BRAGG REFLECTOR LASER**

GaAs Semiconductor Laser Diode  
with integrated grating structure



## PRELIMINARY SPECIFICATION

## DBR Laser

**EYP-DBR-1080-00080-2000-TOC03-0000****Characteristics at  $T_{amb}$  25 °C at Begin Of Life**

Parameter	Symbol	Unit	min	typ	max
Threshold Current	$I_{th}$	mA			70
Operational Current @ $P_{opt} = 80$ mW	$I_{op}$	mA			200
Sidemode Suppression Ratio	SMSR	dB	30	45	
Cavity Length	L	$\mu\text{m}$		2000	
Divergence parallel (FWHM)	$\Theta_{  }$	$^{\circ}$		10	
Divergence perpendicular (FWHM)	$\Theta_{\perp}$	$^{\circ}$		33	
Polarization				TE	
Spatial Mode (transversal)				TEM <sub>00</sub>	
Spectral Mode (longitudinal)				Single Mode	

## Measurement Conditions / Comments

 $P_{opt} = 80$  mW

E field perpendicular to long axis of housing  
fundamental mode

**Monitor Diode**

Parameter	Symbol	Unit	min	typ	max
Monitor Detector Responsivity	$I_{mon} / P_{opt}$	$\mu\text{A} / \text{mW}$	1		10
Reverse Voltage Monitor Diode	$U_{R MD}$	V	3		5
Monitor Linearity	$Lin_{MD}$	%	-20		+20

## Measurement Conditions / Comments

 $U_R = 5$  V, target values $P_{opt} = 10 \dots 80$  mW,  $U_R = 5$  V**Thermoelectric Cooler**

	Symbol	Unit	min	typ	max
Current	I	A			1.8
Voltage	U	V			3.2
Thermal Load	$Q_c$	W			3.1
Temperature Difference	dT	K			50

 $T_{chip} = 25^{\circ}\text{C}$ ;  $P_{opt} = 80$  mW**Thermistor (Standard NTC Type)**

	Symbol	Unit	min	typ	max
Resistance	R	kOhm		10	
Beta Coefficient	$\beta$			3892	

**DISTRIBUTED BRAGG REFLECTOR LASER**

GaAs Semiconductor Laser Diode  
with integrated grating structure



## PRELIMINARY SPECIFICATION

## DBR Laser

**EYP-DBR-1080-00080-2000-TOC03-0000****Package Dimensions**

	Symbol	Unit	min	typ	max
Height of Laser Output above Header	$H_L$	mm		5.25	
Housing Dimension	$l \times w \times h$	mm <sup>3</sup>		38.8 x 25.4 x 9.2	
Pin Length	L	mm	11		

**Package Pinout**

1	Thermoelectric Cooler (+)	5	Laser Diode (Anode)
2	Thermistor	6	Photo Diode (Anode)
3	Thermistor	7	Photo Diode (Cathode)
4	Laser Diode (Cathode)	8	Thermoelectric Cooler (-)

bottom view

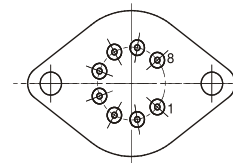
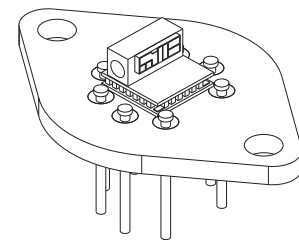
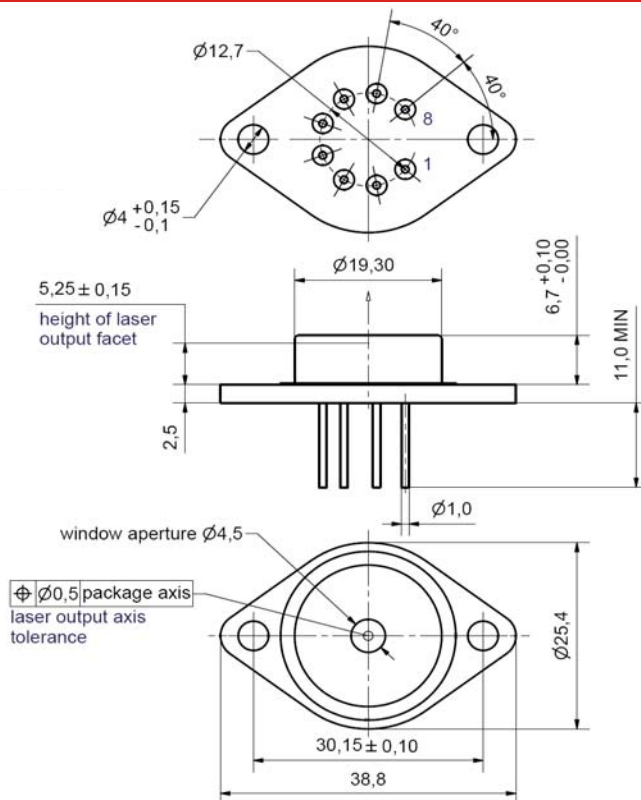
**Package Drawings**

**DISTRIBUTED BRAGG REFLECTOR LASER**

GaAs Semiconductor Laser Diode  
with integrated grating structure



## PRELIMINARY SPECIFICATION

## DBR Laser

**EYP-DBR-1080-00080-2000-TOC03-0000****Typical Measurement Results**

Output Power vs. Current

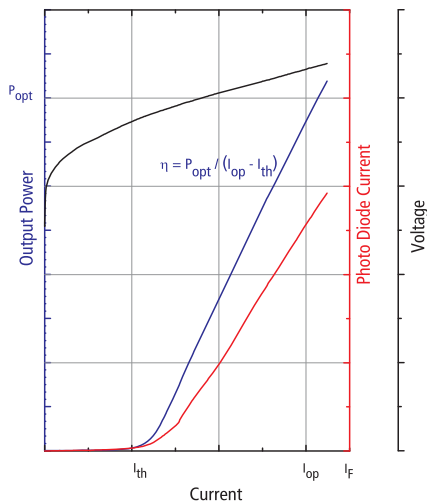

Spectra at Specified Optical Output Power

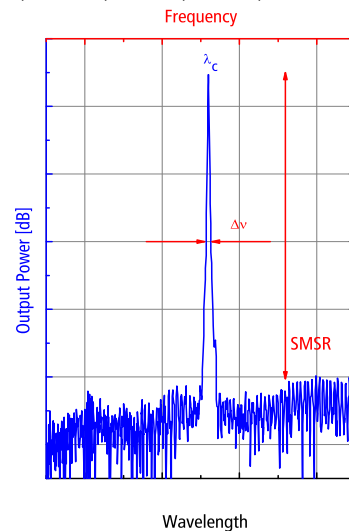

Performance figures, data and any illustrative material provided in this specification are typical and must be specifically confirmed in writing by eagleyard Photonics before they become applicable to any particular order or contract. In accordance with the eagleyard Photonics policy of continuous improvement specifications may change without notice.

**Unpacking, Installation and Laser Safety**

Unpacking the laser diodes should only be done at electrostatic safe workstations (EPA). Though protection against electro static discharge (ESD) is implemented in the laser package, charges may occur at surfaces. Please store this product in its original package at a dry, clean place until final use. During device installation, ESD protection has to be maintained.

The DFB diode type is known to be sensitive against optical feedback, so an optical isolator may be required in some cases. Operating at moderate temperatures on proper heat sinks will contribute to a long lifetime of the diode.

The laser emission from this diode is close to the invisible infrared region of the electromagnetic spectrum. Avoid direct and/or indirect exposure to the free running beam. Collimating the free running beam with optics as common in optical instruments will increase threat to the human eye.

Each laser diode will come with an individual test protocol verifying the parameters given in this document.



eagleyard Photonics GmbH

Rudower Chaussee 29 (IGZ)  
12490 Berlin GERMANY

fon +49. 30. 6392 4520  
fax +49. 30. 6392 4529

info@eagleyard.com  
www.eagleyard.com

**eagleyard**  
PHOTONICS  
We focus on power.