

DISTRIBUTED FEEDBACK LASER

GaAs Semiconductor Laser Diode
with integrated grating structure

**PRELIMINARY SPECIFICATION****DBR Laser****EYP-DBR-1063-00100-2000-SOT2-0000****General Product Information**

Product	Application
1063 nm DBR Laser with TO Housing	Spectroscopy
Monitor Diode	Metrology

**Absolute Maximum Ratings**

	Symbol	Unit	min	typ	max
Storage Temperature	T_S	°C	-40		85
Operational Temperature at Case	T_C	°C	-20		75
Forward Current	I_F	mA			250
Reverse Voltage	V_R	V			0
Output Power	P_{opt}	mW			120

Stress in excess of the Absolute Maximum Ratings can cause permanent damage to the device. Operation at the Absolute Maximum Rating for extended periods of time can adversely affect the device reliability and may lead to reduced operational life.

Recommended Operational Conditions

	Symbol	Unit	min	typ	max
Temperature at Case	T_{Chip}	°C	15		40
Forward Current	I_F	mA			230
Output Power	P_{opt}	mW	10		100

total output measured with integrated sphere

Characteristics at $T_{amb} = 25\text{ °C}$ at Begin Of Life

Parameter	Symbol	Unit	min	typ	max
Center Wavelength	λ_C	nm	1061	1063	1064
Spectral Width (FWHM)	$\Delta\nu$	MHz		2	10
Temperature Coefficient of Wavelength	$d\lambda / dT$	nm / K		0.06	
Current Coefficient of Wavelength	$d\lambda / dI$	nm / mA		0.003	
Output Power @ $I_F = 230\text{ mA}$	P_{opt}	mW	100		
Slope Efficiency	S	W / A	0.6	0.8	1.0

Measurement Conditions / Comments

see images on page 4

total output measured with integrated sphere

DISTRIBUTED FEEDBACK LASER

GaAs Semiconductor Laser Diode
with integrated grating structure



PRELIMINARY SPECIFICATION

DBR Laser

EYP-DBR-1063-00100-2000-SOT2-0000**Characteristics at T_{amb} 25 °C at Begin Of Life**

Parameter	Symbol	Unit	min	typ	max
Threshold Current	I_{th}	mA			70
Operational Current @ $P_{opt} = 100$ mW	I_{op}	mA			230
Sidemode Supression Ratio	SMSR	dB		30	
Cavity Length	L	μ m		2000	
Divergence parallel	$\Theta_{ }$	°		10	
Divergence perpendicular	Θ_{\perp}	°		33	
Polarization				TE	
Spatial Mode (transversal)				TEM ₀₀	
Spectral Mode (longitudinal)				Single Mode	

Measurement Conditions / Comments

 $P_{opt} = 100$ mW

E field parallel to Pin 2 - Pin 3 - plane
fundamental mode

Monitor Diode

Parameter	Symbol	Unit	min	typ	max
Monitor Detector Responsivity	I_{mon} / P_{opt}	μ A / mW	1		10
Reverse Voltage Monitor Diode	$U_{R MD}$	V	3		5
Monitor Linearity	Lin_{MD}	%	-20		+20

Measurement Conditions / Comments

 $U_R = 5$ V, target values $P_{opt} = 10 \dots 100$ mW, $U_R = 5$ V

DISTRIBUTED FEEDBACK LASER

GaAs Semiconductor Laser Diode
with integrated grating structure



PRELIMINARY SPECIFICATION

DBR Laser

EYP-DBR-1063-00100-2000-SOT2-0000

Package Dimensions

	Symbol	Unit	min	typ	max
Height of Emission Plane	d_{EP}	mm	3.50	3.65	3.70
Excentricity of Emission Center	R	mm			0.12
Pin Length	l	mm		14	

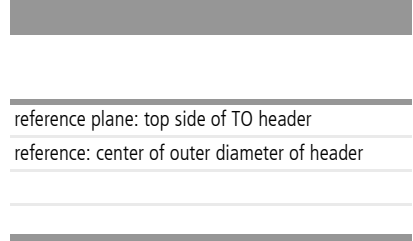

Package Pinout M-Type

Ground	1
Photo Diode (+)	2
Laser (+)	3

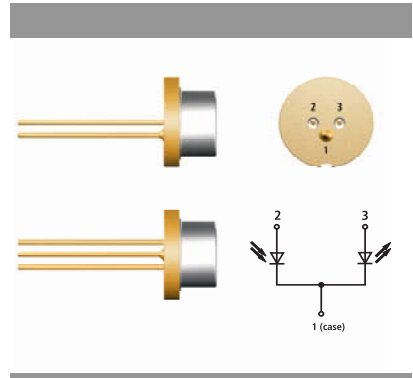

Package Drawings

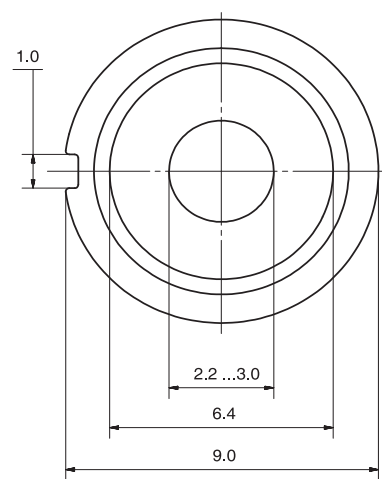
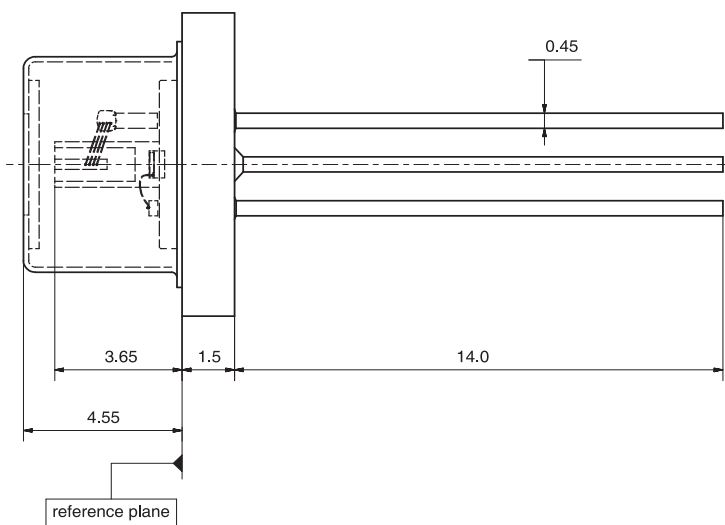

DISTRIBUTED FEEDBACK LASER

GaAs Semiconductor Laser Diode
with integrated grating structure



PRELIMINARY SPECIFICATION

DBR Laser

EYP-DBR-1063-00100-2000-SOT02-0000

Typical Measurement Results

Spectrum

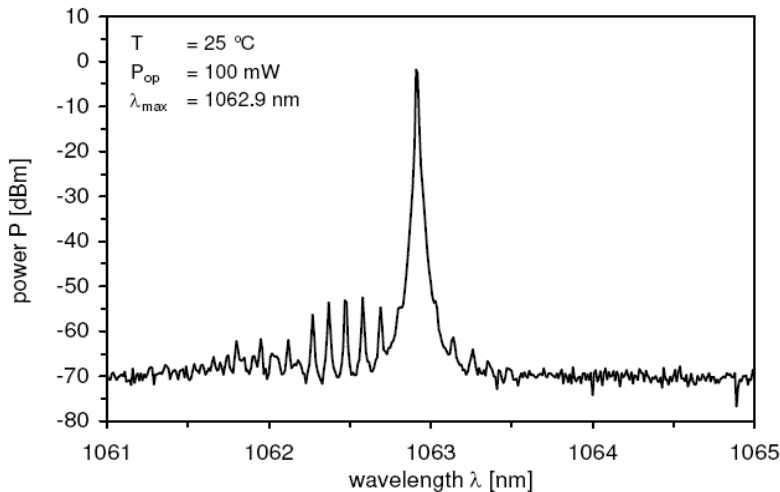

Performance figures, data and any illustrative material provided in this specification are typical and must be specifically confirmed in writing by eagleyard Photonics before they become applicable to any particular order or contract. In accordance with the eagleyard Photonics policy of continuous improvement specifications may change without notice.

Unpacking, Installation and Laser Safety

Unpacking the laser diodes should only be done at electrostatic safe workstations (EPA). Though protection against electro static discharge (ESD) is implemented in the laser package, charges may occur at surfaces. Please store this product in its original package at a dry, clean place until final use. During device installation, ESD protection has to be maintained.

The DFB diode type is known to be sensitive against optical feedback, so an optical isolator may be required in some cases. Operating at moderate temperatures on proper heat sinks will contribute to a long lifetime of the diode.

The laser emission from this diode is close to the invisible infrared region of the electromagnetic spectrum. Avoid direct and/or indirect exposure to the free running beam. Collimating the free running beam with optics as common in optical instruments will increase threat to the human eye.

Each laser diode will come with an individual test protocol verifying the parameters given in this document.

